



Programmed automatic pulling plate chamber filter press

Product Description

Programmed automatic pulling plate chamber filter presses is not manual operation, but a key start or remote control and achieve full automation. Junyi's chamber filter presses are equipped with an intelligent control system with an LCD display of the operating process and a fault warning function. At the same time, the equipment adopts Siemens PLC automatic control and Schneider components to ensure the overall operation of the equipment. In addition, the equipment is equipped with safety devices to ensure safe operation.



Product Features

A、 **Filtration pressure** < 0.5Mpa

B、 **Filtration temperature** : 45°C/ room temperature; 80°C/ high temperature; 100°C/ High temperature. The raw material ratio of different temperature production filter plates is not the same, and the thickness of filter plates is not the same.

C-1、 **Discharge method - open flow**: Faucets need to be installed below the left and right sides of each filter plate, and a matching sink. Open flow is used for liquids that are not recovered.

C-2、Liquid discharge method close flow: Under the feed end of the filter press, there are two close flow outlet main pipes, which are connected with the liquid recovery tank. If the liquid needs to be recovered, or if the liquid is volatile, smelly, flammable and explosive, dark flow is used.

D-1、Selection of filter cloth material: The pH of the liquid determines the material of the filter cloth. PH1-5 is acidic polyester filter cloth, PH8-14 is alkaline polypropylene filter cloth. The viscous liquid or solid is preferred to choose twill filter cloth, and the non-viscous liquid or solid is selected plain filter cloth.

D-2、Selection of filter cloth mesh: The fluid is separated, and the corresponding mesh number is selected for different solid particle sizes. Filter cloth mesh range 100-1000 mesh. Micron to mesh conversion (1UM = 15,000 mesh---in theory).

E、Rack surface treatment: PH value neutral or weak acid base; The surface of the filter press frame is sandblasted first, and then sprayed with primer and anti-corrosion paint. The PH value is strong acid or strong alkaline, the surface of the filter press frame is sandblasted, sprayed with primer, and the surface is wrapped with stainless steel or PP plate.

F、Filter cake washing: When solids need to be recovered, the filter cake is strongly acidic or alkaline; When the filter cake needs to be washed with water, please send an email to inquire about the washing method.

G、Filter press feeding pump selection: The solid-liquid ratio, acidity, temperature and characteristics of the liquid are different, so different feed pumps are required. Please send email to inquire.

Filter Press Model Guidance					
Liquid name	Solid-liquid ratio (%)	Specific gravity of solids	Material status	PH value	Solid particle size (mesh)
Temperature (°C)	Recovery of liquids/solids	Water content of filter cake	Working hours/day	Capacity/day	Whether the liquid evaporates or not

Feeding process

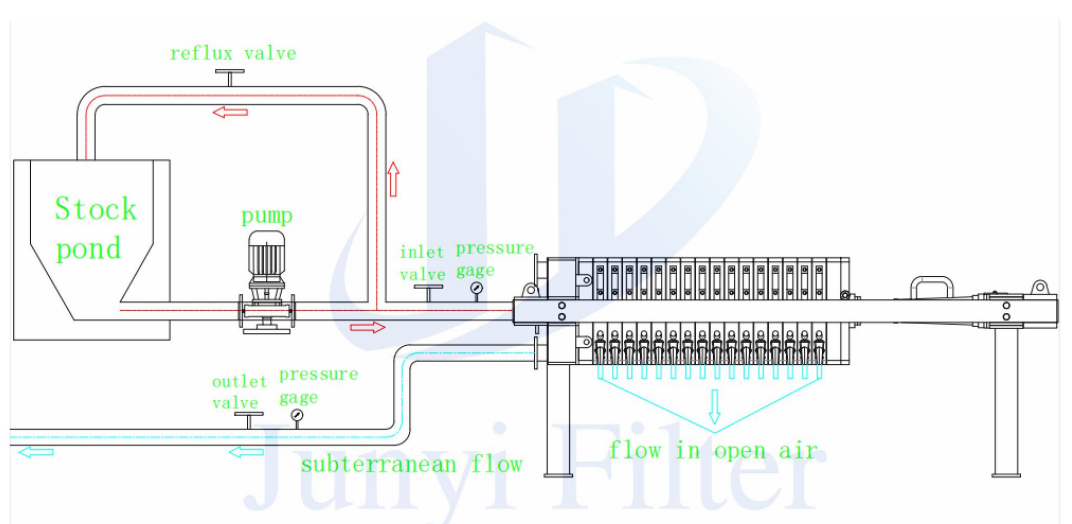

Application Industries

It is widely used in solid-liquid separation process in petroleum, chemical, dyestuff, metallurgy, pharmacy, food, coal washing, inorganic salt, alcohol, chemical, metallurgy, pharmacy, light industry, coal, food, textile, environmental protection, energy and other industries.

Filter press ordering instructions

1. Refer to the filter press selection guide, filter press overview, specifications and models, select the model and supporting equipment according to the needs.

For example: Whether the filter cake is washed or not, whether the effluent is open or close, whether the rack is corrosion-resistant or not, the mode of operation, etc., must be specified in the contract.

1. According to the special needs of customers, our company can design and produce non-standard models or customized products.

3. The product pictures provided in this document are for reference only. In case of changes, we will not give any notice and the actual order will prevail.

Dimension Drawing of Programmed automatic pulling plate chamber filter press

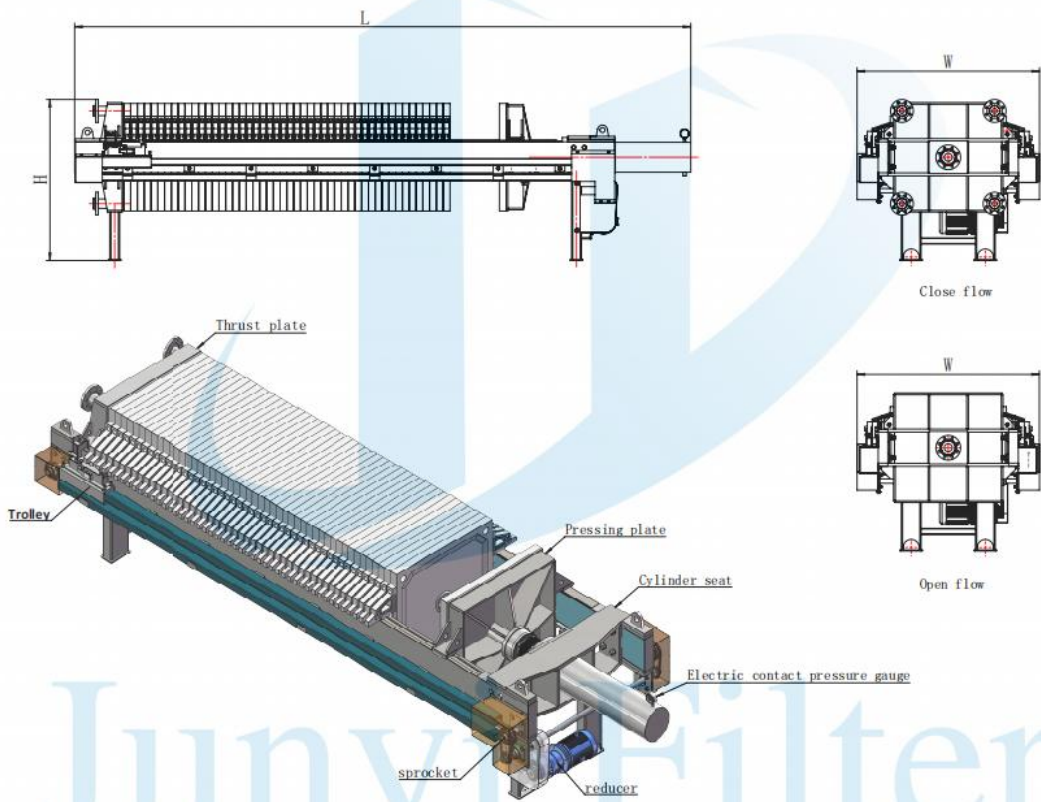

Juny Filter

Model	Filter area (m ²)	Plate Size (mm)	Chamber volume (L)	Plate Qty (pcs)	Weight (Kg)	Motor power (KW)	Overall dimension (mm)			Inlet Size (a)	Outlet/close flow size (b)	Outlet/open flow size
							Length (L)	Width (W)	Height (H)			
JYFPCA-4-450	4	450	60	9	830	2.2	1960	700	900	DN50	DN50	G1/2
JYFPCA-8-450	8		120	19	920		2465					
JYFPCA-10-450	10		150	24	9800		2710					
JYFPCA-12-450	12		180	29	1010		2980					
JYFPCA-16-450	16		240	36	1120		3465					
JYFPCA-15-700	15	700	225	18	1710	2.2	2665	900	1100	DN65	DN50	G1/2
JYFPCA-20-700	20		300	24	1960		2970					
JYFPCA-30-700	30		450	37	2315		3610					
JYFPCA-40-700	40		600	49	2588		4500					
JYFPCA-30-870	30		450	23	2946		3280					
JYFPCA-40-870	40	870	600	30	3390	4.0	3670	1200	1300	DN80	DN65	G1/2
JYFPCA-50-870	50		750	38	3950		4210					
JYFPCA-60-870	60		900	46	4390		4650					
JYFPCA-80-870	80		1200	62	5330		5500					
JYFPCA-50-1000	50		745	29	3960		4060					
JYFPCA-60-1000	60	1000×1000	1050	35	4510	4.0	4810	1500	1400	DN80	DN65	G 3/4
JYFPCA-80-1000	80		1200	47	4968		5200					
JYFPCA-100-1000	100		1500	58	5685		5900					
JYFPCA-120-1000	120		1800	70	6320		6560					
JYFPCA-100-1250	100		1250	1480	38		7960					
JYFPCA-140-1250	140	2090		53	9050	6030						
JYFPCA-160-1250	160	2380		60	10490	6520						
JYFPCA-200-1250	200	2980		75	13060	7480						
JYFPCA-250-1250	250	3735		93	15850	8680						
JYFPCA-200-1500	200	1500×1500	2960	51	18300	7.5	6500	2200	1900	DN 200	DN 100	G 1
JYFPCA-300-1500	300		4430	75	24130		8230					
JYFPCA-350-1500	350		5190	87	27200		8670					
JYFPCA-400-1500	400		5950	101	30100		9980					
JYFPCA-500-1500	500		7460	125	36250		11660					
JYFPCA-600-2000	600	2000	12000	87	45800	11.0	11200	3000	2600	200*2	DN 125	G 1
JYFPCA-700-2000	700		14000	101	49600		12350					
JYFPCA-800-2000	800		16000	109	53100		13480					
JYFPCA-900-2000	900	2000	18000	129	57900	11.0	14690	3000	2600	200*2	DN 125	G 1
JYFPCA-1000-2000	1000		20000	141	61500		15810					

Hoisting diagram of filter press

Filter board hoisting diagram

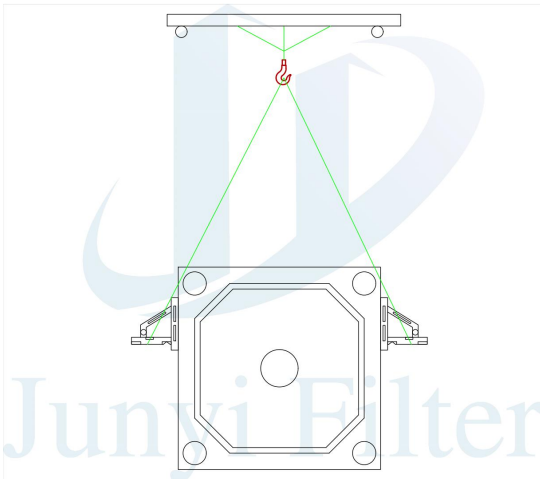
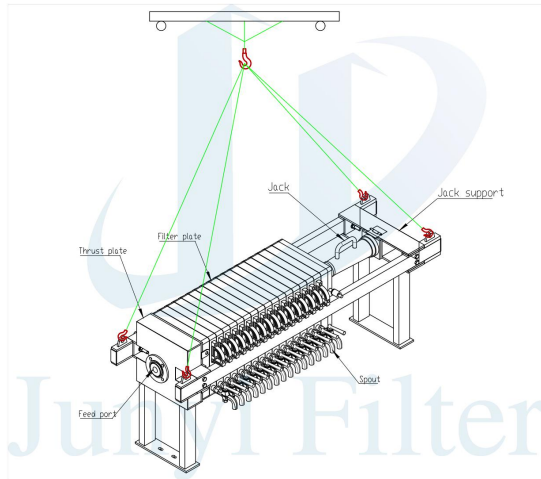

Requirements for use of filter presses

1. According to the process requirements to make pipeline connection, and do water inlet test, detect the air tightness of the pipeline;
2. For the connection of the input power supply (3 phase + neutral), it is best to use a

ground wire for the electric control cabinet;

3. Connection between control cabinet and surrounding equipment. Some wires has been connected. The output line terminals of the control cabinet are labeled. Refer to the circuit diagram to check the wiring and connect it. If there is any looseness in the fixed terminal, compress again;

4. Fill the hydraulic station with 46 # hydraulic oil, the hydraulic oil should be seen in the tank observation window. If the filter press operates continuously for 240 hours, replace or filter the hydraulic oil;

5. Installation of cylinder pressure gauge. Use a wrench to avoid manual rotation during installation. Use an O-ring at the connection between the pressure gauge and the oil cylinder;

6. The first time the oil cylinder runs, the motor of the hydraulic station should be rotated clockwise (indicated on the motor). When the oil cylinder is pushed forward, the pressure gauge base should discharge air, and the oil cylinder should be repeatedly pushed forward and backward (the upper limit pressure of the pressure gauge is 10Mpa) and air should be discharged simultaneously;

7. The filter press runs for the first time, select the manual state of control cabinet to run different functions respectively; After the functions are normal, you can select the automatic state;

8. Installation of filter cloth. During the trial operation of the filter press, the filter plate should be equipped with filter cloth in advance. Install the filter cloth on the filter plate to ensure that the filter cloth is flat and there are no creases or overlaps. Manually push the filter plate to ensure that the filter cloth is flat.

9. During the operation of the filter press, if an accident occurs, the operator presses the emergency stop button or pulls the emergency rope;

Main faults and troubleshooting methods

Fault phenomenon	Fault Principle	Troubleshooting
Severe noise or unstable pressure in the hydraulic system	1、 The oil pump is empty or the oil suction pipe is blocked.	Oil tank refueling, solve suction pipe leakage
	2、 The sealing surface of the filter plate is caught with misc.	Clean sealing surfaces
	3、 Air in the oil circuit	Exhaust air
	4、 Oil pump damaged or worn	Replace or repair
	5、 The relief valve is unstable	Replace or repair
	6、 Pipe vibration	Tightening or reinforcing
Insufficient or no pressure in the hydraulic system	1、 Oil pump damage	Replace or repair
	2. Pressure adjusted incorrectly	recalibration

		3、 Oil viscosity is too low	Replacement of oil
		4、 There is a leak in the oil pump system	Repair after examination
Insufficient pressure compression	cylinder during	1、 Damaged or stuck high pressure relief valve	Replace or repair
		2 、 Damaged reversing valve	Replace or repair
		3 、 Damaged large piston seal	replacement
		4、 Damaged small piston "O" seal	replacement
		5、 Damaged oil pump	Replace or repair
		6 、 Pressure adjusted incorrectly	recalibrate
Insufficient pressure when returning	cylinder	1、 Damaged or stuck low pressure relief valve	Replace or repair
		2 、 Damaged small piston seal	replacement
		3 、 Damaged small piston "O" seal	replacement
Piston crawling		Air in the oil circuit	Replace or repair
Serious transmission noise		1、 Bearing damage	replacement
		2、 Gear striking or wearing	Replace or repair
Serious leakage between plates and frames		1. Plate and frame deformation	replacement
		2 、 Debris on sealing surface	Clean
		3 、 Filter cloth with folds, overlaps, etc.	Qualified for finishing or replacement
		4 、 Insufficient compression force	Appropriate increase in compression force
The plate and frame are broken or deformed		1、 Filter pressure too high	turn down the pressure
		2 、 High material temperature	Appropriately lowered temperatures
		3、 Compression force too high	Adjust the compression force appropriately
		4、 Filtering too fast	Reduced filtration rate
		5、 Clogged feed hole	Cleaning the feed hole
		6、 Stopping in the middle of filtration	Do not stop in the middle of filtration
The replenishment system works frequently		1 、 The hydraulic control check valve is not tightly closed	replacement

	2、 Leakage in the cylinder	Replacement of cylinder seals
Hydraulic reversing valve failure	Spool stuck or damaged	Disassemble and clean or replace the directional valve
The trolley can't be pulled back because of the back and forth impact.	1、Low oil motor oil circuit pressure	adjust
	2、 The pressure relay pressure is low	adjust
Failure to follow procedures	Failure of a component of the hydraulic system, electrical system	Repair or replace symptomatically after inspection
Diaphragm damage	1、 insufficient air pressure	Reduced press pressure
	2、 Insufficient feed	Pressing after filling the chamber with material
	3、 A foreign object has punctured the diaphragm.	foreign matter removal
Bending damage to main beam	1、 Poor or uneven foundations	Refurbish or redo

Tel. +86 021-51863216 +86 13916593699

Email. junyifilter@junyigl.com

Address: Shanghai China

Shanghai Junyi filtration equipment Co., LTD