

Mechanical compression filter press

Product Description

Mechanical compression filter press is driven by an electric motor to drive the reducer, through the transmission parts to push the compression plate to press the filter plate. The compression screw and fixing nut are designed with a reliable self-locking helix angle, which ensures reliability and stability during compression. At the same time, automatic control is achieved with a comprehensive motor protector, which can protect the motor from overheating and overload.



Product Features

A、 **Filtration pressure** < 0.5Mpa

B、 **Filtration temperature** : 45°C/ room temperature; 80°C/ high temperature; 100°C/ High temperature. The raw material ratio of different temperature production filter plates is not the same, and the thickness of filter plates is not the same.

C-1、 **Discharge method - open flow**: Faucets need to be installed below the left and right sides of each filter plate, and a matching sink. Open flow is used for liquids that are not recovered.

C-2、 **Liquid discharge method close flow**: Under the feed end of the filter press, there are two close flow outlet main pipes, which are connected with the liquid recovery tank. If the liquid needs to be recovered, or if the liquid is volatile, smelly, flammable and explosive, dark flow is used.

D-1、 **Selection of filter cloth material**: The pH of the liquid determines the material of the filter cloth. PH1-5 is acidic polyester filter cloth, PH8-14 is alkaline polypropylene filter cloth. The viscous liquid or solid is preferred to choose twill filter cloth, and the non-viscous liquid or solid is selected plain filter cloth.

D-2、 **Selection of filter cloth mesh**: The fluid is separated, and the corresponding mesh number is selected for different solid particle sizes. Filter cloth mesh range 100-1000 mesh. Micron to mesh

conversion (1UM = 15,000 mesh---in theory).

E、 **Rack surface treatment:** PH value neutral or weak acid base; The surface of the filter press frame is sandblasted first, and then sprayed with primer and anti-corrosion paint. The PH value is strong acid or strong alkaline, the surface of the filter press frame is sandblasted, sprayed with primer, and the surface is wrapped with stainless steel or PP plate.

Liquid name	Solid-liquid ratio (%)	Specific gravity of solids	Material status	PH value	Solid particle size (mesh)
Temperature (°C)	Recovery of liquids/solids	Water content of filter cake	Working hours/day	Capacity/day	Whether the liquid evaporates or not

Feeding process

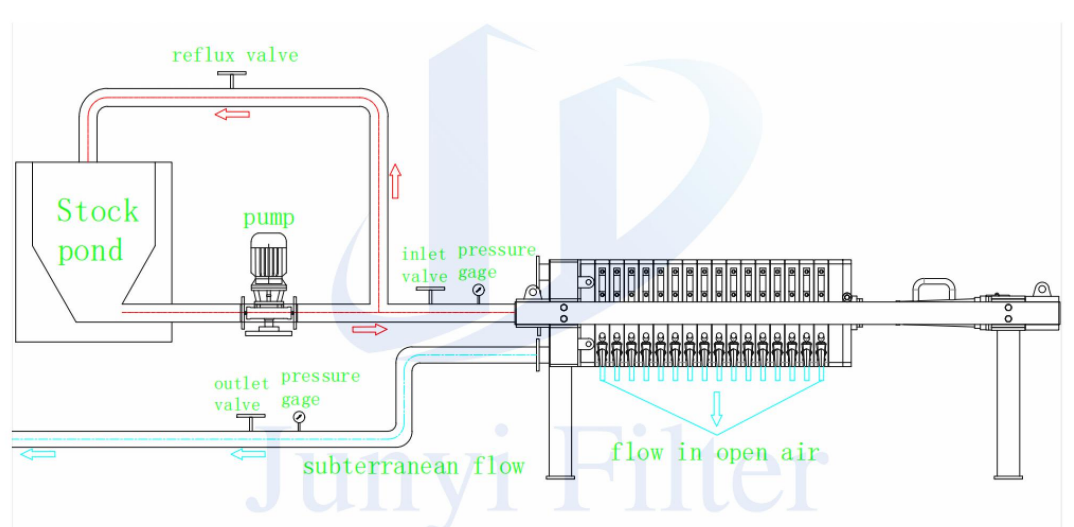

Application Industries

It is widely used in solid-liquid separation process in petroleum, chemical, dyestuff, metallurgy, pharmacy, food, coal washing, inorganic salt, alcohol, chemical, metallurgy, pharmacy, light industry, coal, food, textile, environmental protection, energy and other industries.

Filter press ordering instructions

1. Refer to the filter press selection guide, filter press overview, specifications and models, select the model and supporting equipment according to the needs.

For example: Whether the filter cake is washed or not, whether the effluent is open or close, whether the rack is corrosion-resistant or not, the mode of operation, etc., must be specified in the contract.

1. According to the special needs of customers, our company can design and produce non-standard models or customized products.

3. The product pictures provided in this document are for reference only. In case of changes, we will not give any notice and the actual order will prevail.

Dimension Drawing of Mechanical compression filter press

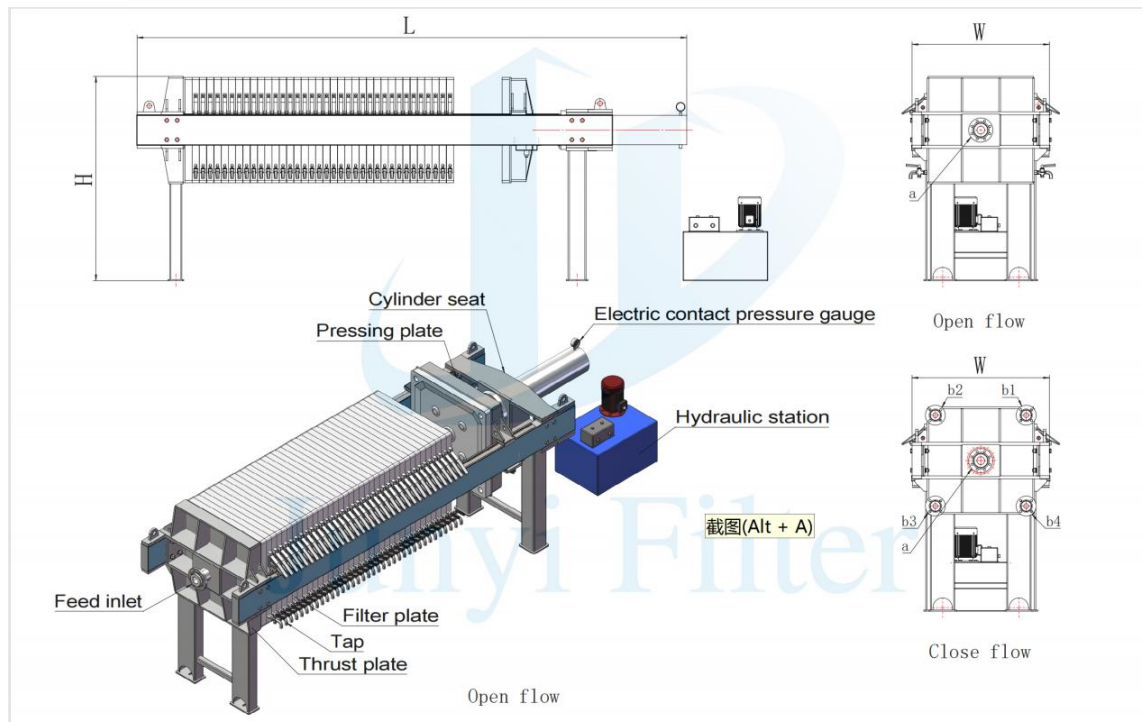

Model	Filter Area m ²	Plate Size (mm)	Chamber volume (L)	Plate Qty (pcs)	Overall Weight Kg	Motor Power Kw	Overall dimension (mm)			Inlet Size (a)	Outlet/close flow size (b)	Outlet/open flow size
							Length (L)	Width (W)	Height (H)			
JYFPCH-4-450	4	450 ×	60	9	830	2.2	1960	700	900	DN50	DN50	G1/2
JYFPCH-8-450	8		120	19	920		2465					
JYFPCH-10-450	10		150	24	9800		2710					
JYFPCH-12-450	12		180	29	1010		2980					
JYFPCH-16-450	16		240	36	1120		3465					
JYFPCH-15-700	15	700 ×	225	18	1710	2.2	2665	900	1100	DN65	DN50	G1/2
JYFPCH-20-700	20		300	24	1960		2970					
JYFPCH-30-700	30		450	37	2315		3610					
JYFPCH-40-700	40		600	49	2588		4500					
JYFPCH-30-870	30		450	23	2380		3280					
JYFPCH-40-870	40	870 ×	600	30	2725	2.2	3670	1200	1300	DN80	DN65	G1/2
JYFPCH-50-870	50		750	38	3118		4210					
JYFPCH-60-870	60		900	46	3512		4650					
JYFPCH-80-870	80		1200	62	4261		5530					
JYFPCH-50-1000	50		1000× 1000	745	28		3960					
JYFPCH-60-1000	60	1050		34	4510	4810						
JYFPCH-80-1000	80	1200		46	4968	5200						
JYFPCH-100-1000	100	1500		57	5685	5900						
JYFPCH-120-1000	120	1800		69	6320	6560						
JYFPCH-100-1250	100	1250 ×	1480	38	7960	5.5	5120	1800	1600	DN 125	DN 80	G3/4
JYFPCH-140-1250	140		2090	53	8860		6090					
JYFPCH-180-1250	180		2665	67	9560		7010					
JYFPCH-200-1250	200		2980	75	11060		7460					
JYFPCH-250-1250	250		3735	95	13850		8720					

Hoisting diagram of filter press

Filter board hoisting diagram

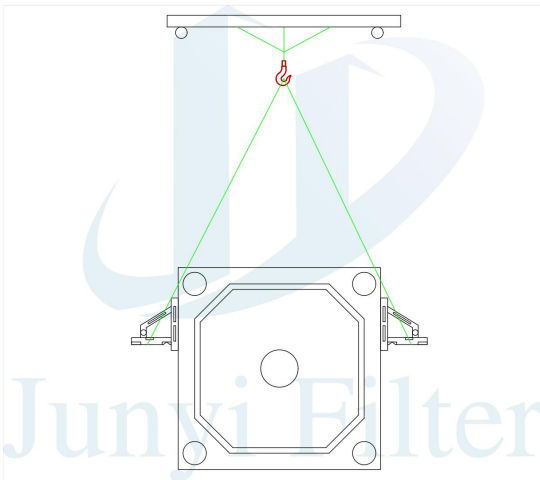
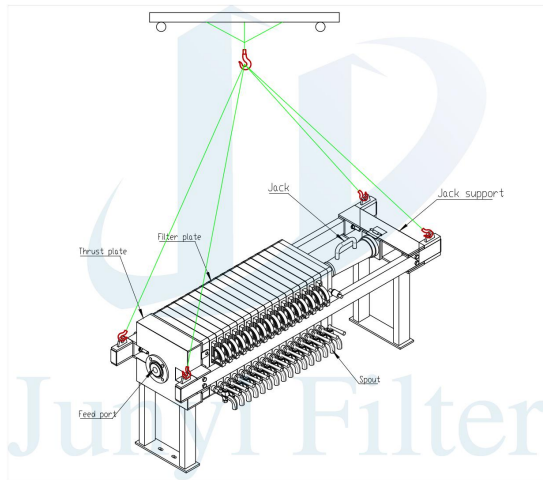

Requirements for use of filter presses

1. According to the process requirements to make pipeline connection, and do water inlet test, detect the air tightness of the pipeline;
2. For the connection of the input power supply (3 phase + neutral), it is best to use a ground wire for the electric control cabinet;
3. Connection between control cabinet and surrounding equipment. Some wires has been connected. The output line terminals of the control cabinet are labeled. Refer to the circuit diagram to check the wiring and connect it. If there is any looseness in the fixed terminal, compress again;

4. Fill the hydraulic station with 46 # hydraulic oil, the hydraulic oil should be seen in the tank observation window. If the filter press operates continuously for 240 hours, replace or filter the hydraulic oil;
5. Installation of cylinder pressure gauge. Use a wrench to avoid manual rotation during installation. Use an O-ring at the connection between the pressure gauge and the oil cylinder;
6. The first time the oil cylinder runs, the motor of the hydraulic station should be rotated clockwise (indicated on the motor). When the oil cylinder is pushed forward, the pressure gauge base should discharge air, and the oil cylinder should be repeatedly pushed forward and backward (the upper limit pressure of the pressure gauge is 10Mpa) and air should be discharged simultaneously;
7. The filter press runs for the first time, select the manual state of control cabinet to run different functions respectively; After the functions are normal, you can select the automatic state;
8. Installation of filter cloth. During the trial operation of the filter press, the filter plate should be equipped with filter cloth in advance. Install the filter cloth on the filter plate to ensure that the filter cloth is flat and there are no creases or overlaps. Manually push the filter plate to ensure that the filter cloth is flat.
9. During the operation of the filter press, if an accident occurs, the operator presses the emergency stop button or pulls the emergency rope;

Main faults and troubleshooting methods

Fault phenomenon	Fault Principle	Troubleshooting
Severe noise or unstable pressure in the hydraulic system	1、 The oil pump is empty or the oil suction pipe is blocked.	Oil tank refueling, solve suction pipe leakage
	2、 The sealing surface of the filter plate is caught with misc.	Clean sealing surfaces
	3、 Air in the oil circuit	Exhaust air
	4、 Oil pump damaged or worn	Replace or repair
	5、 The relief valve is unstable	Replace or repair
	6、 Pipe vibration	Tightening or reinforcing
Insufficient or no pressure in the hydraulic system	1、 Oil pump damage	Replace or repair
	2. Pressure adjusted incorrectly	recalibration
	3、 Oil viscosity is too low	Replacement of oil
	4、 There is a leak in the oil pump system	Repair after examination
Insufficient cylinder pressure during	1、 Damaged or stuck high pressure relief valve	Replace or repair

compression	2 、 Damaged reversing valve	Replace or repair
	3 、 Damaged large piston seal	replacement
	4 、 Damaged small piston "O" seal	replacement
	5、 Damaged oil pump	Replace or repair
	6 、 Pressure adjusted incorrectly	recalibrate
Insufficient cylinder pressure when returning	1、 Damaged or stuck low pressure relief valve	Replace or repair
	2、 Damaged small piston seal	replacement
	3 、 Damaged small piston "O" seal	replacement
Piston crawling	Air in the oil circuit	Replace or repair
Serious transmission noise	1、 Bearing damage	replacement
	2、 Gear striking or wearing	Replace or repair
Serious leakage between plates and frames	1. Plate and frame deformation	replacement
	2 、 Debris on sealing surface	Clean
	3、 Filter cloth with folds, overlaps, etc.	Qualified for finishing or replacement
	4 、 Insufficient compression force	Appropriate increase in compression force
The plate and frame are broken or deformed	1、 Filter pressure too high	turn down the pressure
	2 、 High material temperature	Appropriately lowered temperatures
	3、 Compression force too high	Adjust the compression force appropriately
	4、 Filtering too fast	Reduced filtration rate
	5、 Clogged feed hole	Cleaning the feed hole
	6、 Stopping in the middle of filtration	Do not stop in the middle of filtration
The replenishment system works frequently	1 、 The hydraulic control check valve is not tightly closed	replacement
	2、 Leakage in the cylinder	Replacement of cylinder seals
Hydraulic reversing valve failure	Spool stuck or damaged	Disassemble and clean or replace the directional valve

The trolley can't be pulled back because of the back and forth impact.	1、Low oil motor oil circuit pressure	adjust
	2、The pressure relay pressure is low	adjust
Failure to follow procedures	Failure of a component of the hydraulic system, electrical system	Repair or replace symptomatically after inspection
Diaphragm damage	1、insufficient air pressure	Reduced press pressure
	2、Insufficient feed	Pressing after filling the chamber with material
	3、A foreign object has punctured the diaphragm.	foreign matter removal
Bending damage to main beam	1、Poor or uneven foundations	Refurbish or redo

Tel. +86 021-51863216 +86 13916593699

Email. junyifilter@junyigl.com

Address: Shanghai China

Shanghai Junyi filtration equipment Co., LTD