

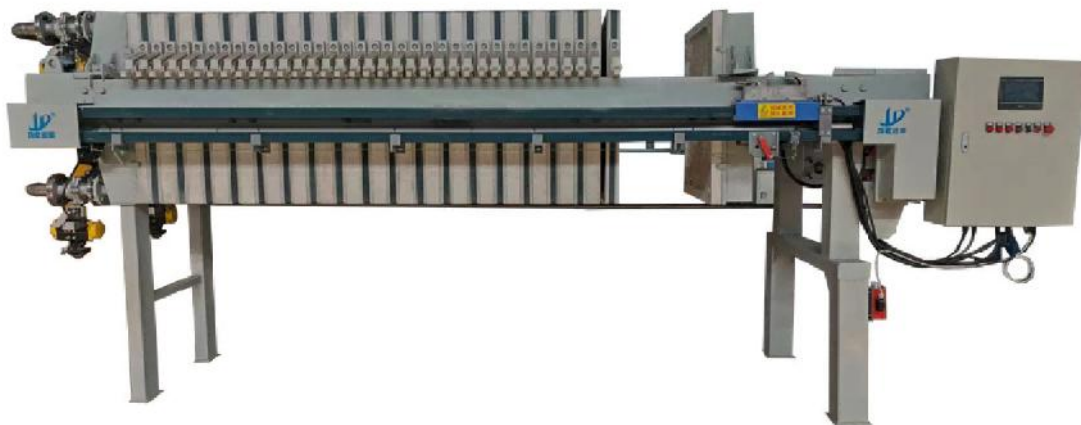

# Automatic High Pressure Diaphragm Filter Press

## Product Description

Junyi Automatic High Pressure Diaphragm Filter Press consists of diaphragm plates and chamber filter plates arranged to form a filter chamber. After filtration, a cake is formed inside the chamber, and then air or pure water is injected into the diaphragm filter plate. At this time, the membrane of the diaphragm expands to press the cake inside the filter chamber sufficiently to reduce the water content. For the filtration of viscous materials and users who require high water content, this machine has its unique characteristics. The filter plate is made of reinforced polypropylene moulding, the diaphragm and the polypropylene plate are inlaid together, which is strong and firm, not easy to fall off, and has a long service life.



## Product Features

A-1、 **Filtration pressure:** 0.8Mpa; 1.0Mpa; 1.3Mpa; 1.6Mpa. (Optional)

A-2、 **Diaphragm pressing pressure:** 1.0Mpa; 1.3Mpa; 1.6Mpa. (Optional)

B、 **Filtration temperature :** 45°C/ room temperature; 80°C/ high temperature; 100°C/ High temperature.

C-1、 **Discharge method - open flow:** Faucets need to be installed below the left and right sides of each filter plate, and a matching sink. Open flow is used for liquids that are not recovered.

C-2、 **Liquid discharge method -close flow:** Under the feed end of the filter press, there are two close flow outlet main pipes, which are connected with the liquid recovery tank. If the liquid needs to be recovered, or if the liquid is volatile, smelly, flammable and explosive, dark flow is used.

D-1、 **Selection of filter cloth material:** The PH of the liquid determines the material of the filter cloth. PH1-5 is acidic polyester filter cloth, PH8-14 is alkaline polypropylene filter cloth. The viscous liquid or solid is preferred to choose twill filter cloth, and the non-viscous liquid or solid is selected plain filter cloth.

D-2、 **Selection of filter cloth mesh:** The fluid is separated, and the corresponding mesh number is selected for different solid particle sizes. Filter cloth mesh range 100-1000 mesh. Micron to mesh conversion (1UM = 15,000 mesh---in theory).

E、 **Rack surface treatment:** PH value neutral or weak acid base; The surface of the filter press frame is sandblasted first, and then sprayed with primer and anti-corrosion paint. The PH value is strong acid or strong alkaline, the surface of the filter press frame is sandblasted, sprayed with primer, and the surface is wrapped with stainless steel or PP plate.

F、 **Filter cake washing:** When solids need to be recovered, the filter cake is strongly acidic or alkaline; When the filter cake needs to be washed with water, please send an email to inquire about the washing method.

G、 **Diaphragm filter press operation:** Automatic Hydraulic Pressing; Automatic Filter Plate Pulling; Filter Plate Vibrating Cake Discharge; Automatic Filter Cloth Rinsing System.

H、 **Filter press feeding pump selection:** The solid-liquid ratio, acidity, temperature and characteristics of the liquid are different, so different feed pumps are required. Please send email to inquire.

Liquid name	Solid-liquid ratio (%)	Specific gravity of solids	Material status	PH value	Solid particle size (mesh)
Temperature (°C)	Recovery of liquids/solids	Water content of filter cake	Working hours/day	Capacity/day	Whether the liquid evaporates or not

### Feeding process

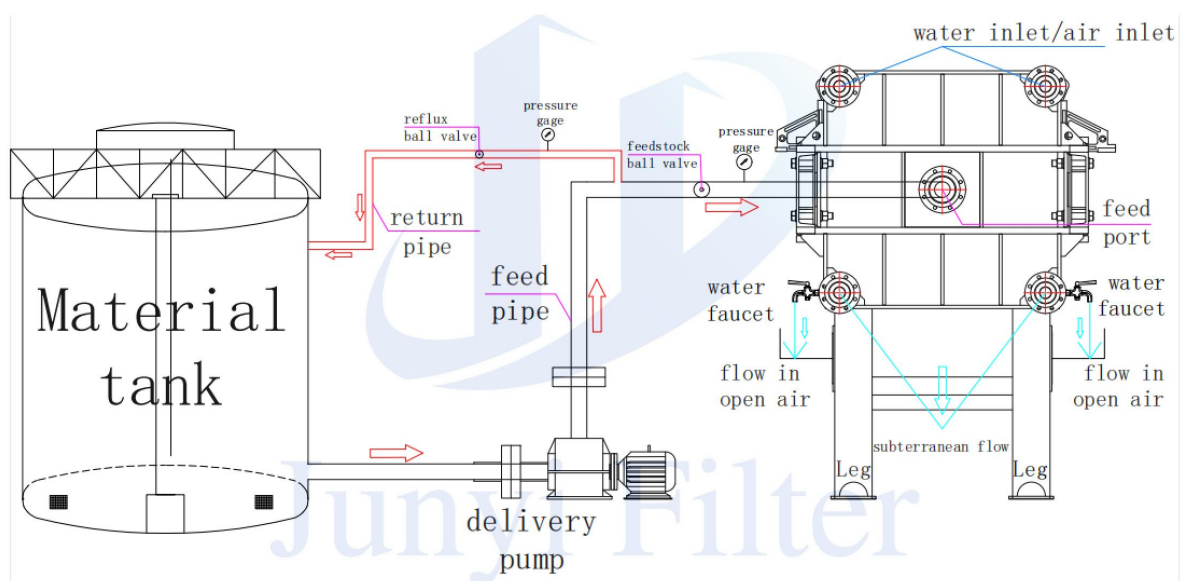

## Application Industries

It is widely used in solid-liquid separation process in petroleum, chemical, dyestuff, metallurgy, pharmacy, food, coal washing, inorganic salt, alcohol, chemical, metallurgy, pharmacy, light industry, coal, food, textile, environmental protection, energy and other industries.

### Filter press ordering instructions

1. Refer to the filter press selection guide, filter press overview, specifications and models, select the model and supporting equipment according to the needs.

For example: Whether the filter cake is washed or not, whether the effluent is open or close, whether the rack is corrosion-resistant or not, the mode of operation, etc., must be specified in the contract.

1. According to the special needs of customers, our company can design and produce non-standard models or customized products.

3. The product pictures provided in this document are for reference only. In case of changes, we will not give any notice and the actual order will prevail.

## Dimension Drawing of Automatic High Pressure Diaphragm Filter Press

### Press

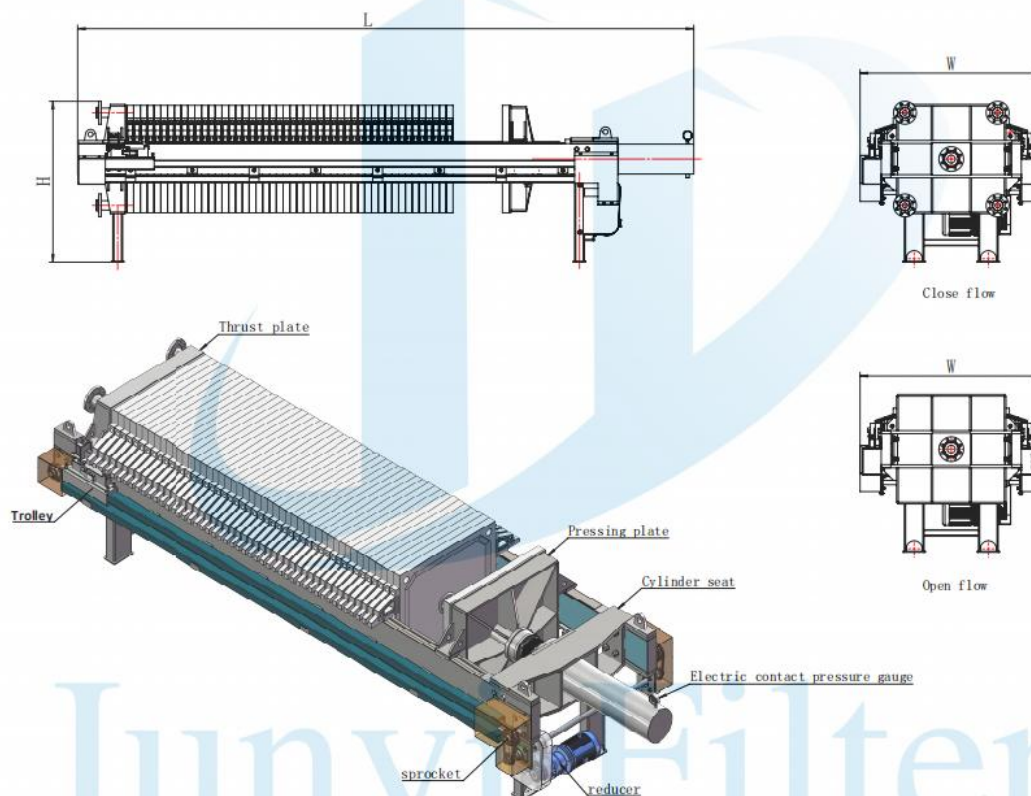

Model	Filter area (m <sup>2</sup> )	Plate Size (mm)	Chamber volume (L)	Plate Qty (pcs)	Weight (Kg)	Motor power (KW)	Overall dimension (mm)			Inlet Size (a)	Outlet/close flow size (b)	Outlet/open flow size
							Length (L)	Width (W)	Height (H)			
JYFPMA-30-870	30	870 × 870	412	23	2380	4.0	3510	1250	1300	DN80	DN65	G1/2
JYFPMA-40-870	40		520	29			3990					
JYFPMA-50-870	50		653	37			4510					
JYFPMA-60-870	60		798	45			5030					
JYFPMA-80-870	80		1083	61			5870					
JYFPMA-50-1000	50	1000 × 1000	680	27	4386	4.0	4380	1500	1400	DN80	DN65	G 3/4
JYFPMA-60-1000	60		819	33			4890					
JYFPMA-80-1000	80		1108	45			5660					
JYFPMA-100-1000	100		1386	57			6520					
JYFPMA-120-1000	120		1675	69			7360					
JYFPMA-100-1250	100	1250 × 1250	1850	39	10650	5.5	5530	1800	1600	DN 125	DN 80	G3/4
JYFPMA-120-1250	120		2060	47			6175					
JYFPMA-150-1250	150		2517	57			6926					
JYFPMA-200-1250	200		3427	75			8310					
JYFPMA-250-1250	250		4256	93			9680					
JYFPMA-200-1500	200	1500 × 1500	3813	51	23120	7.5	7250	2300	1850	DN 200	DN 100	G 1
JYFPMA-300-1500	300		5149	75			8830					
JYFPMA-350-1500	350		6082	87			10230					
JYFPMA-400-1500	400		6882	101			11360					
JYFPMA-500-1500	500		8615	125			13350					
JYFPMA-600-2000	600	2000 × 2000	12000	87	49690	11	13130	3000	2600	DN 200*2	DN 125	G 1
JYFPMA-700-2000	700		14000	101			14490					
JYFPMA-800-2000	800		16000	109			15870					
JYFPMA-900-2000	900		18000	129			17250					
JYFPMA-1000-2000	1000		20000	141			18630					

## Hoisting diagram of filter press

## Filter board hoisting diagram

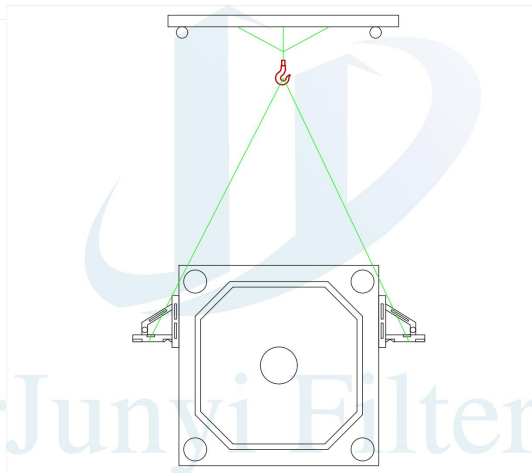
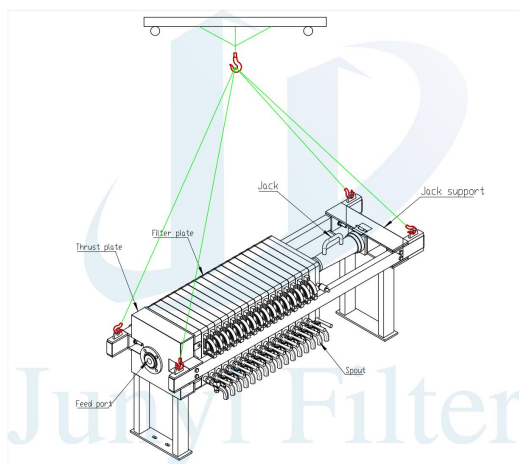

## Requirements for use of filter presses

1. According to the process requirements to make pipeline connection, and do water inlet test, detect the air tightness of the pipeline;
2. For the connection of the input power supply (3 phase + neutral), it is best to use a ground wire for the electric control cabinet;
3. Connection between control cabinet and surrounding equipment. Some wires has been connected. The output line terminals of the control cabinet are labeled. Refer to the circuit diagram to check the wiring and connect it. If there is any looseness in the fixed terminal, compress again;
4. Fill the hydraulic station with 46 # hydraulic oil, the hydraulic oil should be seen in

the tank observation window. If the filter press operates continuously for 240 hours, replace or filter the hydraulic oil;

5. Installation of cylinder pressure gauge. Use a wrench to avoid manual rotation during installation. Use an O-ring at the connection between the pressure gauge and the oil cylinder;

6. The first time the oil cylinder runs, the motor of the hydraulic station should be rotated clockwise (indicated on the motor). When the oil cylinder is pushed forward, the pressure gauge base should discharge air, and the oil cylinder should be repeatedly pushed forward and backward (the upper limit pressure of the pressure gauge is 10Mpa) and air should be discharged simultaneously;

7. The filter press runs for the first time, select the manual state of control cabinet to run different functions respectively; After the functions are normal, you can select the automatic state;

8. Installation of filter cloth. During the trial operation of the filter press, the filter plate should be equipped with filter cloth in advance. Install the filter cloth on the filter plate to ensure that the filter cloth is flat and there are no creases or overlaps. Manually push the filter plate to ensure that the filter cloth is flat.

9. During the operation of the filter press, if an accident occurs, the operator presses the emergency stop button or pulls the emergency rope;

### Main faults and troubleshooting methods

Fault phenomenon	Fault Principle	Troubleshooting
Severe noise or unstable pressure in the hydraulic system	1、 The oil pump is empty or the oil suction pipe is blocked.	Oil tank refueling, solve suction pipe leakage
	2、 The sealing surface of the filter plate is caught with misc.	Clean sealing surfaces
	3、 Air in the oil circuit	Exhaust air
	4、 Oil pump damaged or worn	Replace or repair
	5、 The relief valve is unstable	Replace or repair
	6、 Pipe vibration	Tightening or reinforcing
Insufficient or no pressure in the hydraulic system	1、 Oil pump damage	Replace or repair
	2. Pressure adjusted incorrectly	recalibration
	3、 Oil viscosity is too low	Replacement of oil
	4、 There is a leak in the oil pump system	Repair after examination
Insufficient cylinder pressure during compression	1、 Damaged or stuck high pressure relief valve	Replace or repair
	2、 Damaged reversing	Replace or repair

	valve	
	3、 Damaged large piston seal	replacement
	4、 Damaged small piston "O" seal	replacement
	5、 Damaged oil pump	Replace or repair
	6 、 Pressure adjusted incorrectly	recalibrate
Insufficient cylinder pressure when returning	1、 Damaged or stuck low pressure relief valve	Replace or repair
	2、 Damaged small piston seal	replacement
	3、 Damaged small piston "O" seal	replacement
Piston crawling	Air in the oil circuit	Replace or repair
Serious transmission noise	1、 Bearing damage	replacement
	2、 Gear striking or wearing	Replace or repair
Serious leakage between plates and frames	1. Plate and frame deformation	replacement
	2 、 Debris on sealing surface	Clean
	3、 Filter cloth with folds, overlaps, etc.	Qualified for finishing or replacement
	4 、 Insufficient compression force	Appropriate increase in compression force
The plate and frame are broken or deformed	1、 Filter pressure too high	turn down the pressure
	2 、 High material temperature	Appropriately lowered temperatures
	3、 Compression force too high	Adjust the compression force appropriately
	4、 Filtering too fast	Reduced filtration rate
	5、 Clogged feed hole	Cleaning the feed hole
	6、 Stopping in the middle of filtration	Do not stop in the middle of filtration
The replenishment system works frequently	1 、 The hydraulic control check valve is not tightly closed	replacement
	2、 Leakage in the cylinder	Replacement of cylinder seals
Hydraulic reversing valve failure	Spool stuck or damaged	Disassemble and clean or replace the directional valve
The trolley can't be pulled	1、 Low oil motor oil circuit	adjust

back because of the back and forth impact.	pressure	
	2 、 The pressure relay pressure is low	adjust
Failure to follow procedures	Failure of a component of the hydraulic system, electrical system	Repair or replace symptomatically after inspection
Diaphragm damage	1、 insufficient air pressure	Reduced press pressure
	2、 Insufficient feed	Pressing after filling the chamber with material
	3 、 A foreign object has punctured the diaphragm.	foreign matter removal
Bending damage to main beam	1 、 Poor or uneven foundations	Refurbish or redo

Tel. +86 021-51863216 +86 13916593699  
 Email. [junyifilter@junyigl.com](mailto:junyifilter@junyigl.com)  
 Address: Shanghai China  
 Shanghai Junyi filtration equipment Co., LTD