

### Product Description

The filter chamber of the stainless steel plate and frame filter press is composed of a stainless steel filter plate and a stainless steel filter frame arranged in turn, using the form of upper corner feed. The plate and frame filter press can only be discharged by manually pulling the plate. Stainless steel plate and frame filter press is used for frequent cleaning or replacement of viscous materials and filter cloth. Stainless steel plate frame filter press can be used with filter paper, higher filtration accuracy; Refined filtration or bacterial filtration of wine and edible oils.



### Product Features

- A、 **Filtration pressure:** 0.6Mpa---1.0Mpa
- B、 **Filtration temperature:** 45°C/ room temperature; 100°C/ high temperature; 200°C/ High temperature.
- C、 **Liquid discharge method - close flow:** Under the feed end of the filter press, there are two close flow outlet main pipes, which are connected with the liquid recovery tank. If the liquid needs to be recovered, or if the liquid is volatile, smelly, flammable and explosive, dark flow is used.
- D-1、 **Selection of filter cloth material:** The PH of the liquid determines the material of the filter cloth. PH1-5 is acidic polyester filter cloth, PH8-14 is alkaline polypropylene filter cloth.
- D-2、 **Selection of filter cloth mesh:** The fluid is separated, and the corresponding mesh number is selected for different solid particle sizes. Filter cloth mesh range 100-1000 mesh. Micron to mesh conversion (1UM = 15,000 mesh---in theory).
- D-3、 Stainless steel plate frame filter press can be used with filter paper, higher filtration accuracy.
- E、 **Pressing method:** jack, manual cylinder, electro-mechanical pressing, automatic cylinder pressing.

### Filter Press Model Guidance

Liquid name	Solid-liquid ratio (%)	Specific gravity of solids	Material status	PH value	Solid particle size (mesh)
Temperature (°C)	Recovery of liquids/solids	Water content of filter cake	Working hours/day	Capacity/day	Whether the liquid evaporates or not

### Feeding process

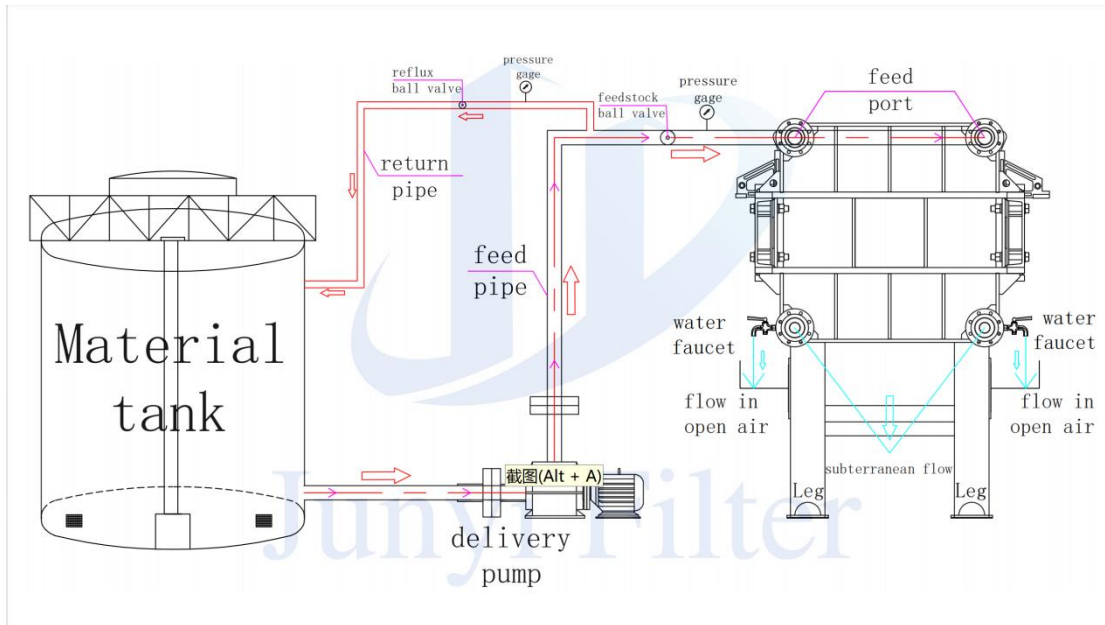

### Application Industries

It is used for fluid filtration with high viscosity and frequent cleaning of filter cloth, such as filtration of medicine, fermentation liquid, liquor, pharmaceutical intermediates, beverage, and dairy products.

#### Filter press ordering instructions

1. Refer to the filter press selection guide, filter press overview, specifications and models, select the model and supporting equipment according to the needs.

For example: Whether the filter cake is washed or not, whether the effluent is open or close, whether the rack is corrosion-resistant or not, the mode of operation, etc., must be specified in the contract.

1. According to the special needs of customers, our company can design and produce non-standard models or customized products.

3. The product pictures provided in this document are for reference only. In case of changes, we will not give any notice and the actual order will prevail.

## Dimension Drawing of Pharmaceutical and biological stainless steel filter presses

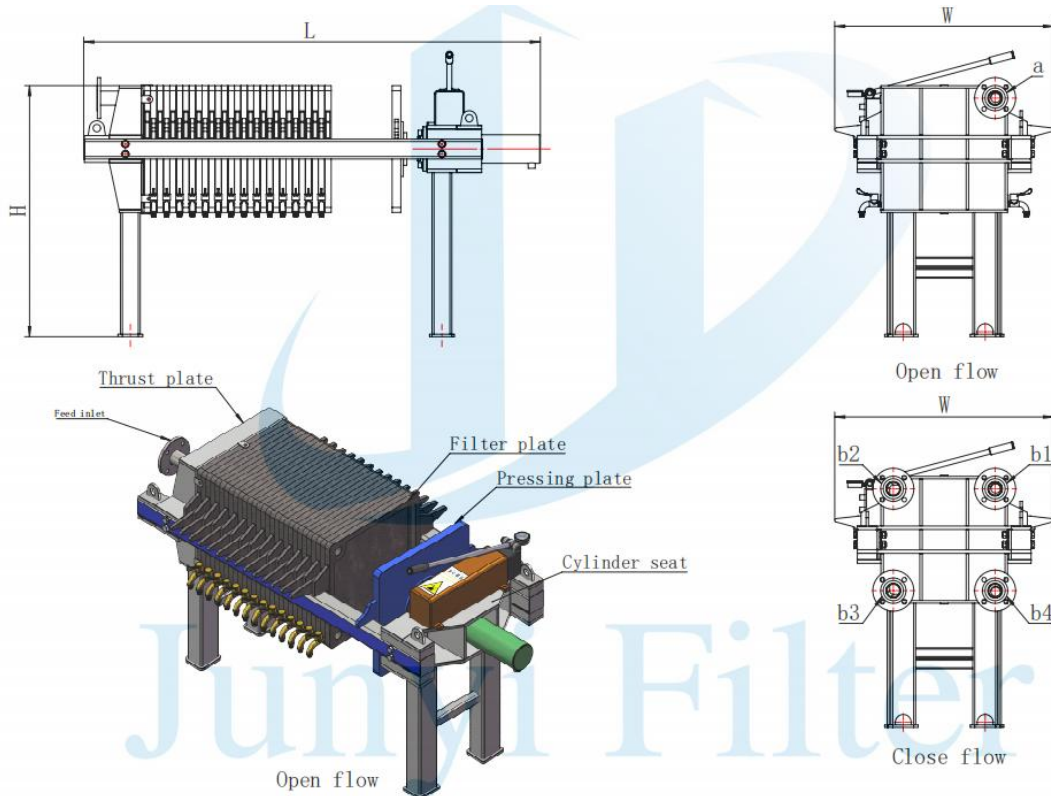

Model	Filter Area (m <sup>2</sup> )	Plate Size (mm)	Chamber volume (L)	Plate Qty (PCS)	Filter Frame Number (PCS)	Overall Weight (Kg)	Motor Power (Kw)	Overall dimension (mm)			Inlet Size (a)	Outlet/closure flow size (b)	Outlet/open flow size
								Length (L)	Width (W)	Height (H)			
JYFPPMP-4-450	4	450	60	9	10	830	2.2	2180	700	900	DN50	DN50	G1/2
JYFPPMP-8-450	8		120	19	20	920		2780					
JYFPPMP-10-450	10		150	24	25	9800		3080					
JYFPPMP-12-450	12		180	29	30	1010		3380					
JYFPPMP-16-450	16		240	39	40	1120		3980					
JYFPPMP-15-700	15	700	225	18	19	1710	2.2	2940	900	1100	DN65	DN50	G1/2
JYFPPMP-20-700	20		300	24	25	1960		3300					
JYFPPMP-30-700	30		450	37	38	2315		4080					
JYFPPMP-40-700	40		600	49	50	2588		4900					
JYFPPMP-30-870	30		450	23	24	2380		3670					
JYFPPMP-40-870	40	870	600	30	31	2725	4.0	4150	1200	1300	DN80	DN65	G1/2
JYFPPMP-50-870	50		750	38	39	3118		4810					
JYFPPMP-60-870	60		900	46	47	3512		5370					
JYFPPMP-80-870	80		1200	62	63	4261		6390					

## Hoisting diagram of filter press      Filter board hoisting diagram

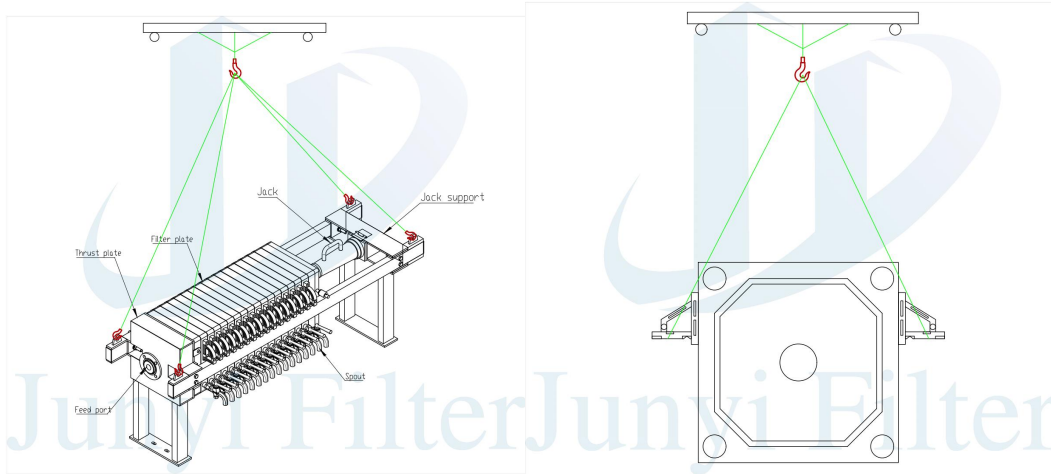

## Requirements for use of filter presses

1. According to the process requirements to make pipeline connection, and do water inlet test, detect the air tightness of the pipeline;
2. For the connection of the input power supply (3 phase + neutral), it is best to use a ground wire for the electric control cabinet;
3. Connection between control cabinet and surrounding equipment. Some wires has been connected. The output line terminals of the control cabinet are labeled. Refer to the circuit diagram to check the wiring and connect it. If there is any looseness in the fixed terminal, compress again;
4. Fill the hydraulic station with 46 # hydraulic oil, the hydraulic oil should be seen in the tank observation window. If the filter press operates continuously for 240 hours, replace or filter the hydraulic oil;
5. Installation of cylinder pressure gauge. Use a wrench to avoid manual rotation during installation. Use an O-ring at the connection between the pressure gauge and the oil cylinder;
6. The first time the oil cylinder runs, the motor of the hydraulic station should be rotated clockwise (indicated on the motor). When the oil cylinder is pushed forward, the pressure gauge base should discharge air, and the oil cylinder should be repeatedly pushed forward and backward (the upper limit pressure of the pressure gauge is 10Mpa) and air should be discharged simultaneously;
7. The filter press runs for the first time, select the manual state of control cabinet to run different functions respectively; After the functions are normal, you can select the automatic state;
8. Installation of filter cloth. During the trial operation of the filter press, the filter plate should be equipped with filter cloth in advance. Install the filter cloth on the filter plate to ensure that the filter cloth is flat and there are no creases or overlaps. Manually push the filter plate to ensure that the filter cloth is flat.
9. During the operation of the filter press, if an accident occurs, the operator presses the emergency stop button or pulls the emergency rope;

## Main faults and troubleshooting methods

Fault phenomenon	Fault Principle	Troubleshooting
Severe noise or unstable pressure in the hydraulic system	1、 The oil pump is empty or the oil suction pipe is blocked.	Oil tank refueling, solve suction pipe leakage
	2、 The sealing surface of the filter plate is caught with misc.	Clean sealing surfaces
	3、 Air in the oil circuit	Exhaust air

	4、 Oil pump damaged or worn	Replace or repair
	5 、 The relief valve is unstable	Replace or repair
	6、 Pipe vibration	Tightening or reinforcing
Insufficient or no pressure in the hydraulic system	1、 Oil pump damage	Replace or repair
	2. Pressure adjusted incorrectly	recalibration
	3、 Oil viscosity is too low	Replacement of oil
	4、 There is a leak in the oil pump system	Repair after examination
Insufficient cylinder pressure during compression	1、 Damaged or stuck high pressure relief valve	Replace or repair
	2 、 Damaged reversing valve	Replace or repair
	3 、 Damaged large piston seal	replacement
	4 、 Damaged small piston "O" seal	replacement
	5、 Damaged oil pump	Replace or repair
	6 、 Pressure adjusted incorrectly	recalibrate
Insufficient cylinder pressure when returning	1 、 Damaged or stuck low pressure relief valve	Replace or repair
	2、 Damaged small piston seal	replacement
	3 、 Damaged small piston "O" seal	replacement
Piston crawling	Air in the oil circuit	Replace or repair
Serious transmission noise	1、 Bearing damage	replacement
	2、 Gear striking or wearing	Replace or repair
Serious leakage between plates and frames	1. Plate and frame deformation	replacement
	2 、 Debris on sealing surface	Clean
	3、 Filter cloth with folds, overlaps, etc.	Qualified for finishing or replacement
	4 、 Insufficient compression force	Appropriate increase in compression force
The plate and frame are broken or deformed	1、 Filter pressure too high	turn down the pressure
	2 、 High material temperature	Appropriately lowered temperatures
	3、 Compression force too high	Adjust the compression force appropriately
	4、 Filtering too fast	Reduced filtration rate
	5、 Clogged feed hole	Cleaning the feed hole
	6、 Stopping in the middle of filtration	Do not stop in the middle of filtration

The replenishment system works frequently	1、 The hydraulic control check valve is not tightly closed	replacement
	2、 Leakage in the cylinder	Replacement of cylinder seals
Hydraulic reversing valve failure	Spool stuck or damaged	Disassemble and clean or replace the directional valve
The trolley can't be pulled back because of the back and forth impact.	1、Low oil motor oil circuit pressure	adjust
	2、 The pressure relay pressure is low	adjust
Failure to follow procedures	Failure of a component of the hydraulic system, electrical system	Repair or replace symptomatically after inspection
Diaphragm damage	1、 insufficient air pressure	Reduced press pressure
	2、 Insufficient feed	Pressing after filling the chamber with material
	3、 A foreign object has punctured the diaphragm.	foreign matter removal
Bending damage to main beam	1、 Poor or uneven foundations	Refurbish or redo

Tel. +86 021-51863216 +86 13916593699

Email. [junyifilter@junyigl.com](mailto:junyifilter@junyigl.com)

Address: Shanghai China

Shanghai Junyi filtration equipment Co., LTD